

**Diagonal 11mm (Type 2/3) CCD Image Sensor for CCIR B/W Video Cameras *Preliminary***

**Description**

The ICX423AL is an interline CCD solid-state image sensor suitable for CCIR B/W video cameras with a diagonal 11mm (Type 2/3) system. Compared with the current product ICX083AL, basic characteristics such as sensitivity and smear are improved drastically and high saturation characteristics are realized.

This chip features a field period readout system and an electronic shutter with variable charge-storage time. This chip is compatible with the pins of the ICX083AL and has the same drive conditions.

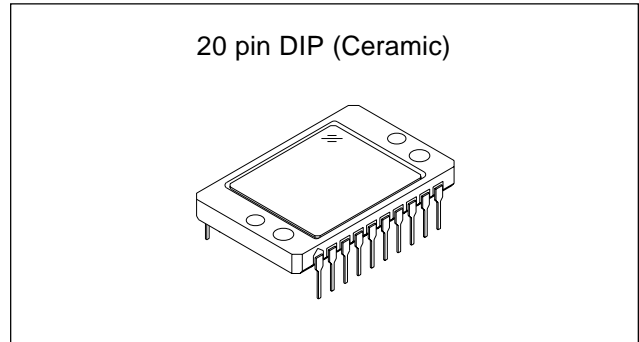

**Features**

- High sensitivity (+3.0dB compared with the ICX083AL)
- Low smear (-10.0dB compared with the ICX083AL)
- High saturation signal (+2.0dB compared with the ICX083AL)
- High resolution and Low dark current
- Excellent antiblooming characteristics
- Continuous variable-speed shutter

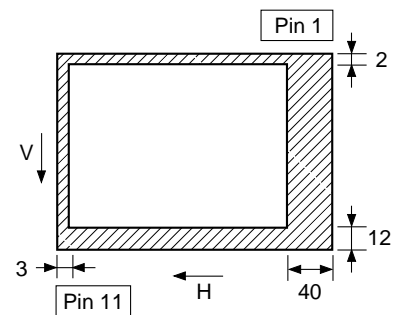

**Optical black position  
(Top View)**

**Device Structure**

- Interline CCD image sensor
- Optical size: Diagonal 11mm (Type 2/3)
- Number of effective pixels: 752 (H) × 582 (V) approx. 440K pixels
- Total number of pixels: 795 (H) × 596 (V) approx. 470K pixels
- Chip size: 10.25mm (H) × 8.5mm (V)
- Unit cell size: 11.6μm (H) × 11.2μm (V)
- Optical black: Horizontal (H) direction: Front 3 pixels, rear 40 pixels  
Vertical (V) direction: Front 12 pixels, rear 2 pixels
- Number of dummy bits: Horizontal 22  
Vertical 1 (even fields only)
- Substrate material: Silicon

Sony reserves the right to change products and specifications without prior notice. This information does not convey any license by any implication or otherwise under any patents or other right. Application circuits shown, if any, are typical examples illustrating the operation of the devices. Sony cannot assume responsibility for any problems arising out of the use of these circuits.

**Block Diagram and Pin Configuration**

(Top view)

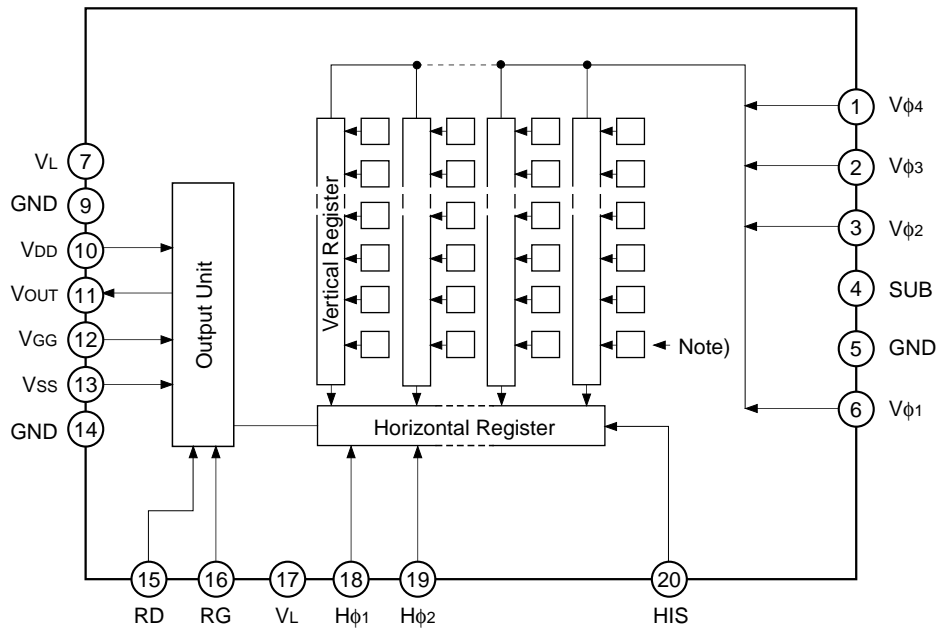

Note) □ : Photo sensor

**Pin Description**

Pin No.	Symbol	Description	Pin No.	Symbol	Description
1	Vφ4	Vertical register transfer clock	11	VOUT	Signal output
2	Vφ3	Vertical register transfer clock	12	VGG	Output amplifier gate bias
3	Vφ2	Vertical register transfer clock	13	VSS	Output amplifier source
4	SUB	Substrate (overflow drain)	14	GND	GND
5	GND	GND	15	RD	Reset drain
6	Vφ1	Vertical register transfer clock	16	RG	Reset gate clock
7	VL	Protective transistor bias	17	VL	Protective transistor bias
8	NC		18	Hφ1	Horizontal register transfer clock
9	GND	GND	19	Hφ2	Horizontal register transfer clock
10	VDD	Output amplifier drain power	20	HIS	Horizontal register input source bias

## Absolute Maximum Ratings

Item		Ratings	Unit	Remarks
Substrate voltage SUB – GND		–0.3 to +55	V	
Supply voltage	HIS, V <sub>DD</sub> , RD, V <sub>OUT</sub> , V <sub>SS</sub> – GND	–0.3 to +20	V	
	HIS, V <sub>DD</sub> , RD, V <sub>OUT</sub> , V <sub>SS</sub> – SUB	–55 to +10	V	
Vertical clock input voltage	Vertical clock input pins – GND	–15 to +20	V	
	Vertical clock input pins – SUB	to +10	V	
Voltage difference between vertical clock input pins		to +15	V	*1
Voltage difference between horizontal clock input pins		to +17	V	
H $\phi$ <sub>1</sub> , H $\phi$ <sub>2</sub> – V $\phi$ <sub>4</sub>		–17 to +17	V	
H $\phi$ <sub>1</sub> , H $\phi$ <sub>2</sub> , RG, V <sub>GG</sub> – GND		–10 to +15	V	
H $\phi$ <sub>1</sub> , H $\phi$ <sub>2</sub> , RG, V <sub>GG</sub> – SUB		–55 to +10	V	
V <sub>L</sub> – SUB		–65 to +0.3	V	
V $\phi$ <sub>1</sub> , V $\phi$ <sub>3</sub> , HIS, V <sub>DD</sub> , RD, V <sub>OUT</sub> – V <sub>L</sub>		–0.3 to +30	V	
RG – V <sub>L</sub>		–0.3 to +24	V	
V $\phi$ <sub>2</sub> , V $\phi$ <sub>4</sub> , V <sub>GG</sub> , V <sub>SS</sub> , H $\phi$ <sub>1</sub> , H $\phi$ <sub>2</sub> – V <sub>L</sub>		–0.3 to +20	V	
Storage temperature		–30 to +80	°C	
Operating temperature		–10 to +60	°C	

\*1 27V (Max.) when clock width < 10 $\mu$ s, clock duty factor < 0.1%.

## Bias Conditions

Item	Symbol	Min.	Typ.	Max.	Unit	Remarks
Output amplifier drain voltage	V <sub>DD</sub>	14.7	15.0	15.3	V	
Reset drain voltage	V <sub>RD</sub>	14.7	15.0	15.3	V	V <sub>RD</sub> = V <sub>DD</sub>
Output amplifier gate voltage	V <sub>GG</sub>	3.8	4.2	4.6	V	
Output amplifier source	V <sub>SS</sub>	Ground with 750 $\Omega$ resistor				$\pm$ 5%
Substrate voltage adjustment range	V <sub>SUB</sub>	9		19	V	*2
Substrate voltage adjustment precision	$\Delta$ V <sub>SUB</sub>	–3		+3	%	
Reset gate clock voltage adjustment range	V <sub>RGL</sub>	0		3.0	V	*2
Reset gate clock voltage adjustment precision	$\Delta$ V <sub>RGL</sub>	–3		+3	%	
Protective transistor bias	V <sub>L</sub>	–11	–10.5	–10	V	*3
Horizontal register input source bias	V <sub>HIS</sub>	14.7	15.0	15.3	V	V <sub>HIS</sub> = V <sub>DD</sub>



## Clock Voltage Conditions

Item	Symbol	Min.	Typ.	Max.	Unit	Waveform diagram	Remarks
Readout clock voltage	$V_{VT}$	14.5	15.0	15.5	V	1	
Vertical transfer clock voltage	$V_{VH1}, V_{VH2}, V_{VH3}, V_{VH4}$	-0.6		0	V	2	$V_{VH} = (V_{VH1} + V_{VH2})/2$
	$V_{VL1}, V_{VL2}, V_{VL3}, V_{VL4}$		-9.6		V	2	$V_{VL} = (V_{VL3} + V_{VL4})/2$
	$V_{\phi V}$	8.9			V	2	$V_{\phi V} = V_{VHN} - V_{VLn}$ (n = 1 to 4)
	$ V_{VH1} - V_{VH2} $			0.2	V	2	
	$V_{VH3} - V_{VH}$	-0.5		0	V	2	
	$V_{VH4} - V_{VH}$	-0.5		0	V	2	
	$V_{VHH}$			0.8	V	2	High-level coupling
	$V_{VHL}$			1.0	V	2	High-level coupling
	$V_{V LH}$			0.8	V	2	Low-level coupling
	$V_{VLL}$			0.8	V	2	Low-level coupling
Horizontal transfer clock voltage	$V_{\phi H}$	6.0		8.0	V	3	
	$V_{HL}$	-3.5		-3.0	V	3	
Reset gata clock voltage	$V_{\phi RG}$	6.0		13.0	V	3	*1
	$V_{RGL}$	0		3.0	V	3	
Substrate clock voltage	$V_{\phi SUB}$	27.0		32.0	V	4	

\*1 The reset gate clock voltage need not be adjusted when the reset gate clock is driven when the specifications are as given below. In this case, the reset gate clock voltage setting indicated on the back of the image sensor has not significance.

Item	Symbol	Min.	Typ.	Max.	Unit	Waveform diagram	Remarks
Reset gate clock voltage	$V_{RGL}$	-0.2	0	0.2	V	3	
	$V_{\phi RG}$	8.5	9.0	9.5	V	3	

**Clock Equivalent Circuit Constant**

Item	Symbol	Min.	Typ.	Max.	Unit	Remarks
Capacitance between vertical transfer clock and GND	$C\phi V1, C\phi V3$		2700		pF	
	$C\phi V2, C\phi V4$		2700		pF	
Capacitance between vertical transfer clocks	$C\phi V12, C\phi V34$		2600		pF	
	$C\phi V23, C\phi V41$		950		pF	
	$C\phi V13$		1000		pF	
	$C\phi V24$		500		pF	
Capacitance between horizontal transfer clock and GND	$C\phi H1, C\phi H2$		47		pF	
Capacitance between horizontal transfer clocks	$C\phi HH$		58		pF	
Capacitance between reset gate clock and GND	$C\phi RG$		7		pF	
Capacitance between substrate clock and GND	$C\phi SUB$		800		pF	
Vertical transfer clock series resistor	$R1, R2, R3, R4$		22		$\Omega$	
Vertical transfer clock ground resistor	$R_{GND}$		3		$\Omega$	
Horizontal transfer clock series resistor	$R\phi H$		10		$\Omega$	

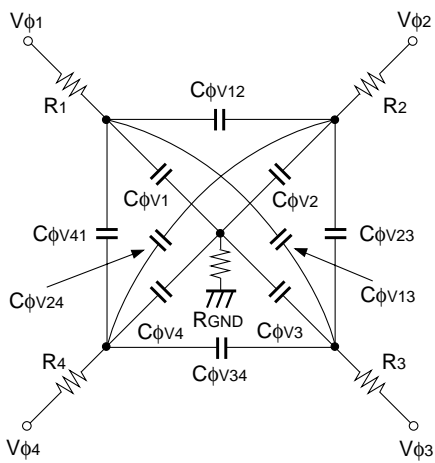

**Vertical transfer clock equivalent circuit**

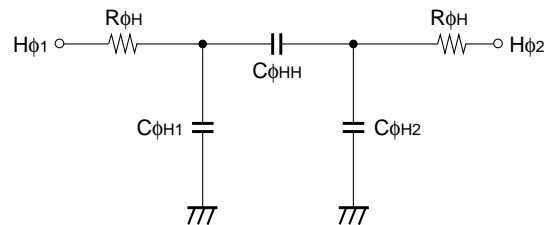

**Horizontal transfer clock equivalent circuit**

Drive Clock Waveform Conditions

(1) Readout clock waveform

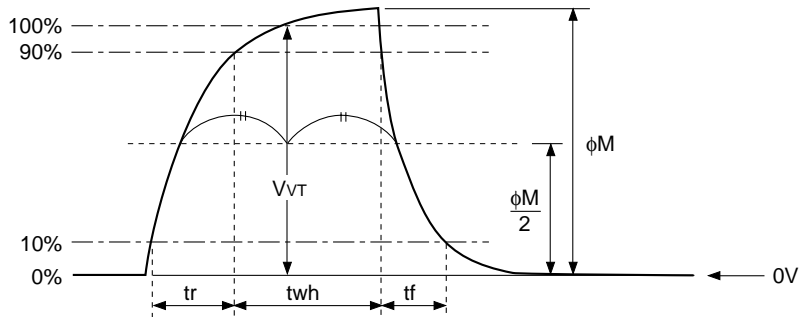

(2) Vertical transfer clock waveform

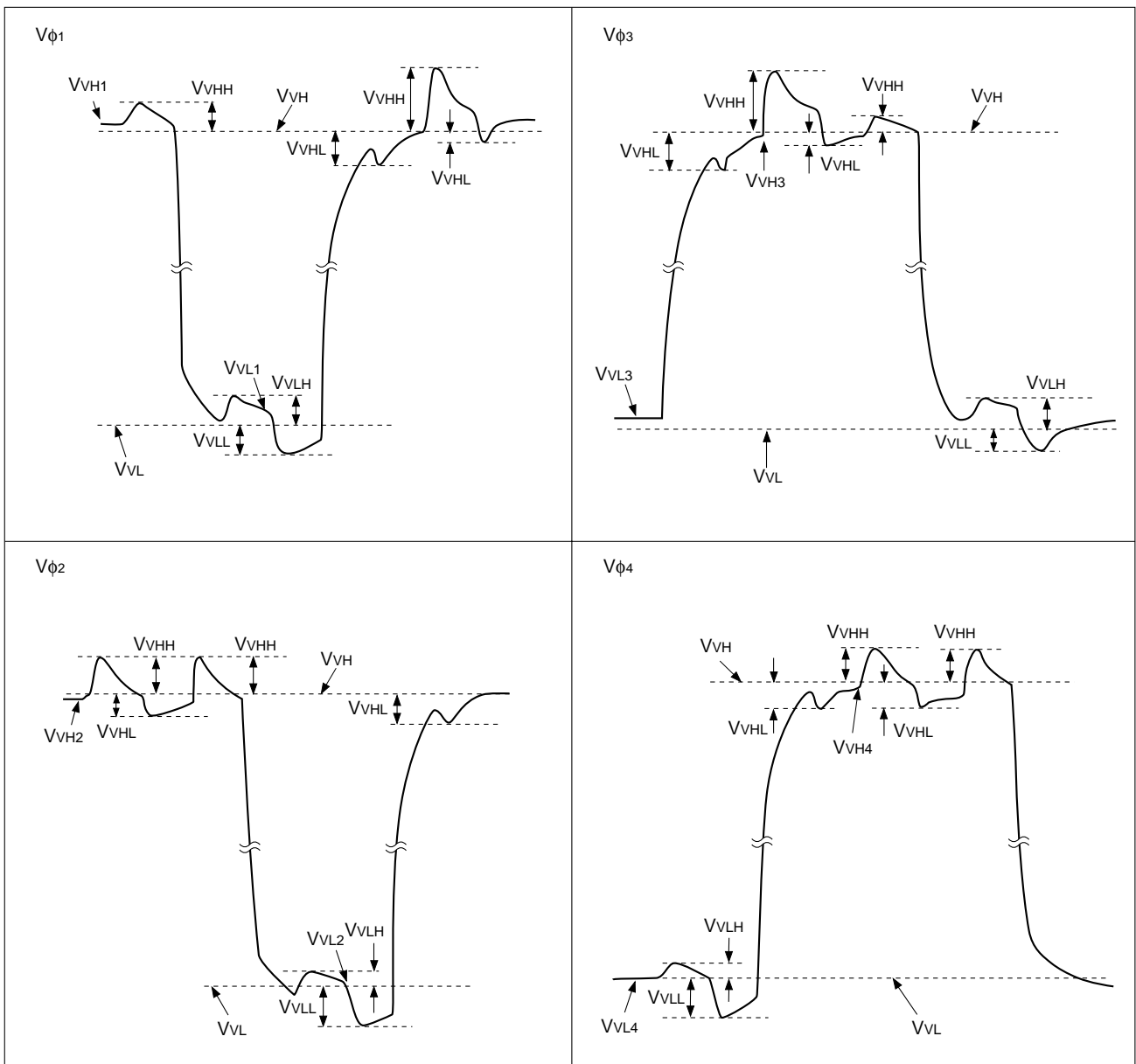

$$V_{VH} = (V_{VH1} + V_{VH2})/2$$

$$V_{VL} = (V_{VL3} + V_{VL4})/2$$

$$V_{\phi n} = V_{VHn} - V_{VLn} \quad (n = 1 \text{ to } 4)$$

(3) Horizontal transfer clock waveform - Reset gate clock waveform

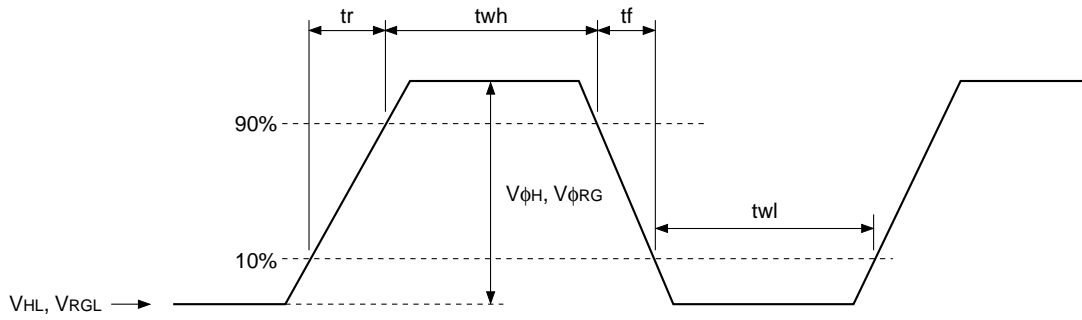

(4) Substrate clock waveform

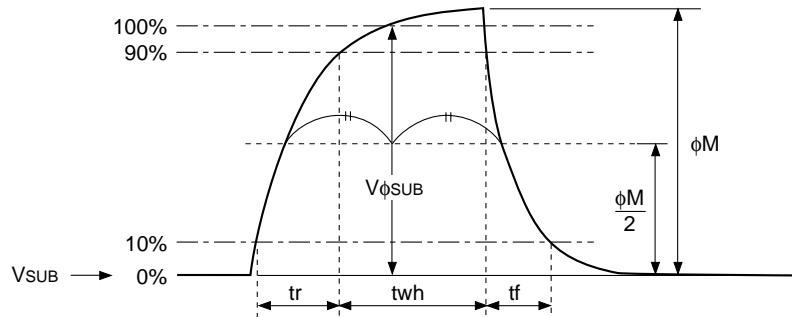

Clock Switching Characteristics

Item	Symbol	twh			twl			tr			tf			Unit	Remarks
		Min.	Typ.	Max.	Min.	Typ.	Max.	Min.	Typ.	Max.	Min.	Typ.	Max.		
Readout clock	$V_T$	2.3	2.5						0.5			0.5		$\mu\text{s}$	During readout
Vertical transfer clock	$V_{\phi 1}, V_{\phi 2}$	62.6			0.74			0.1			0.1			$\mu\text{s}$	During imaging
	$V_{\phi 3}, V_{\phi 4}$	1.3			62.1			0.1			0.1			$\mu\text{s}$	
Horizontal transfer clock	$H_{\phi}$		20		20			15	19		15	19		ns	During imaging
	$H_{\phi 1}$		5.38					0.01			0.01			$\mu\text{s}$	During parallel-serial conversion
	$H_{\phi 2}$				5.38			0.01			0.01			$\mu\text{s}$	
Reset gate clock	$\phi_{RG}$	11	13		51			2.0			2.0			ns	
Substrate clock	$\phi_{SUB}$	1.5	1.8						0.5			0.5		$\mu\text{s}$	During drain charge



**Image Sensor Characteristics**

(Ta = 25°C)

Item	Symbol	Min.	Typ.	Max.	Unit	Measurement method	Remarks
Sensitivity	S	700	1000		mV	1	
Saturation signal	Vsat	1000			mV	2	Ta = 60°C
Smear	Sm		-130	-120	dB	3	
Video signal shading	SH			25	%	4	
Dark signal	Vdt			2	mV	5	Ta = 60°C
Dark signal shading	$\Delta Vdt$			1	mV	6	Ta = 60°C
Flicker	F			5	%	7	
Lag	Lag			0.5	%	8	

**Image Sensor Characteristics Measurement Method**◎ **Measurement conditions**

- 1) In the following measurements, the substrate voltage and the reset gate clock voltage are set to the values indicated on the device, and the device drive conditions are at the typical values of the bias and clock voltage conditions.
- 2) In the following measurements, spot blemishes are excluded and, unless otherwise specified, the optical black (OB) level is used as the reference for the signal output, and the value measured at point [\*A] in the drive circuit example is used.

◎ **Definition of standard imaging conditions**

- 1) Standard imaging condition I:  
Use a pattern box (luminance 706cd/m<sup>2</sup>, color temperature of 3200K halogen source) as a subject. (Pattern for evaluation is not applicable.) Use a testing standard lens with CM500S (t = 1.00mm) as an IR cut filter and image at F8. The luminous intensity to the sensor receiving surface at this point is defined as the standard sensitivity luminous intensity.
- 2) Standard imaging condition II :  
Image a light source (color temperature of 3200K) with a uniformity of brightness within 2% at all angles. Use a testing standard lens with CM500S (t = 1.00mm) as an IR cut filter. The luminous intensity is adjusted to the value indicated in each testing item by the lens diaphragm.

## 1. Sensitivity

Set to standard imaging condition I. After selecting the electronic shutter mode with a shutter speed of 1/250s, measure the signal output (Vs) at the center of the screen and substitute the value into the following formula.

$$S = V_s \times \frac{250}{50} \quad [\text{mV}]$$

## 2. Saturation signal

Set to standard imaging condition II. After adjusting the luminous intensity to 10 times the intensity with average value of signal output, 350mV, measure the minimum value of the signal output.

3. Smear

Set to standard imaging condition II. With the lens diaphragm at F5.6 to F8, adjust the luminous intensity to 500 times the intensity with average value of the signal output, 350mV. When the readout clock is stopped and the charge drain is executed by the electronic shutter at the respective H blankings, measure the maximum value (VSm [mV]) of the signal output and substitute the value into the following formula.

$$S_m = 20 \times \log \left( \frac{V_{Sm}}{350} \times \frac{1}{500} \times \frac{1}{10} \times 100 \right) \text{ [dB]} \text{ (1/10V method conversion value)}$$

4. Video signal shading

Set to standard imaging condition II. With the lens diaphragm at F5.6 to F8, adjust the luminous intensity so that the average value of the signal output is 350mV. Then measure the maximum (Vmax [mV]) and minimum (Vmin [mV]) values of the signal output and substitute the values into the following formula.

$$SH = (V_{max} - V_{min})/350 \times 100 \text{ [%]}$$

5. Dark signal

Measure the average value of the signal output (Vdt [mV]) with the device ambient temperature 60°C and the device in the light-obstructed state, using the horizontal idle transfer level as a reference.

6. Dark signal shading

After measuring 5, measure the maximum (Vdmax [mV]) and minimum (Vdmin [mV]) values of the dark signal output and substitute the values into the following formula.

$$\Delta V_{dt} = V_{dmax} - V_{dmin} \text{ [mV]}$$

7. Flicker

Set to standard imaging condition II. Adjust the luminous intensity so that the average value of the signal output is 350mV, and then measure the difference in the signal level between fields ( $\Delta V_f$  [mV]). Then substitute the value into the following formula.

$$F = (\Delta V_f/350) \times 100 \text{ [%]}$$

8. Lag

Adjust the signal output value generated by strobe light to 350mV. After setting the strobe light so that it strobes with the following timing, measure the residual signal (Vlag). Substitute the value into the following formula.

$$Lag = (V_{lag}/350) \times 100 \text{ [%]}$$

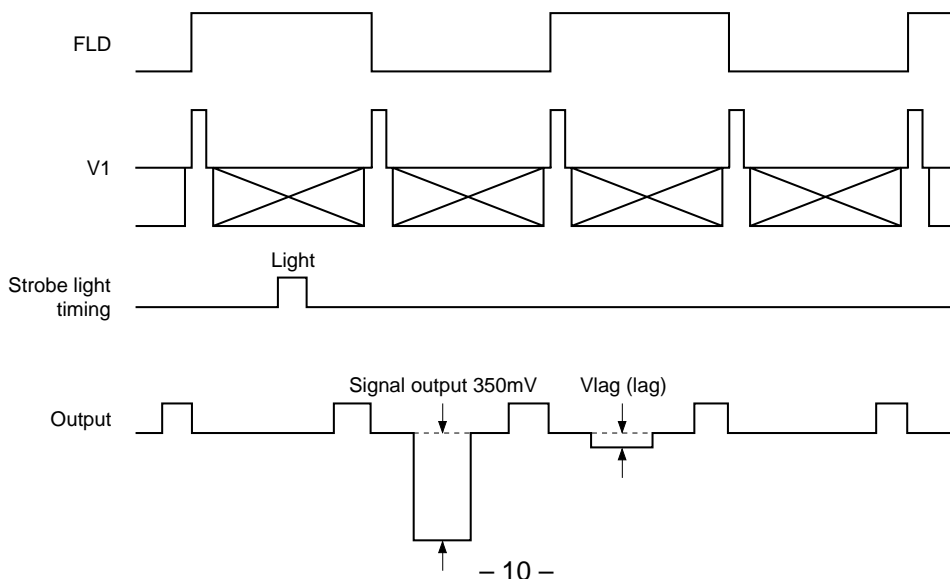

Drive Circuit

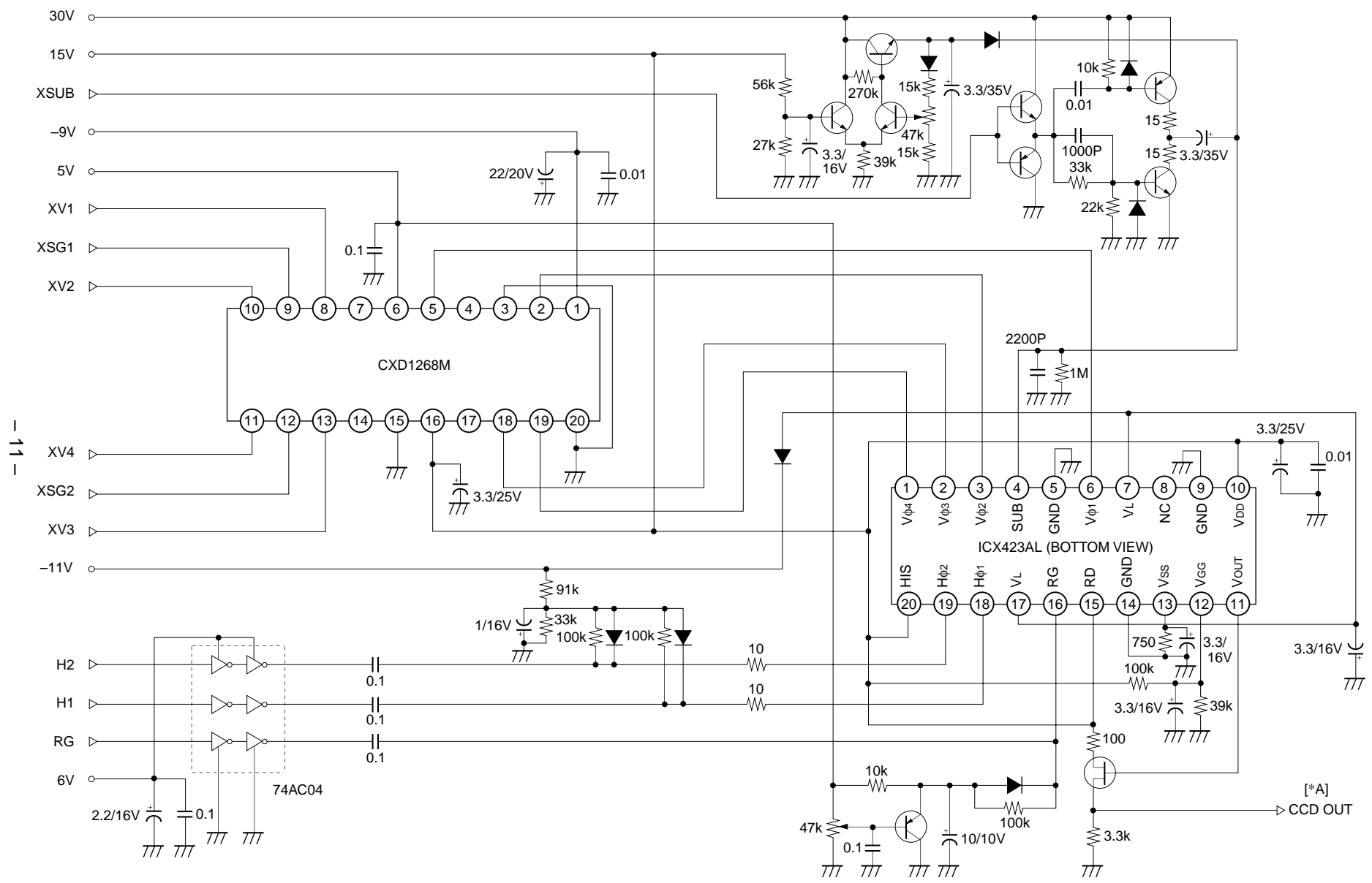

- 11 -

**Spectral Sensitivity Characteristics** (includes lens characteristics, excludes light source characteristics)

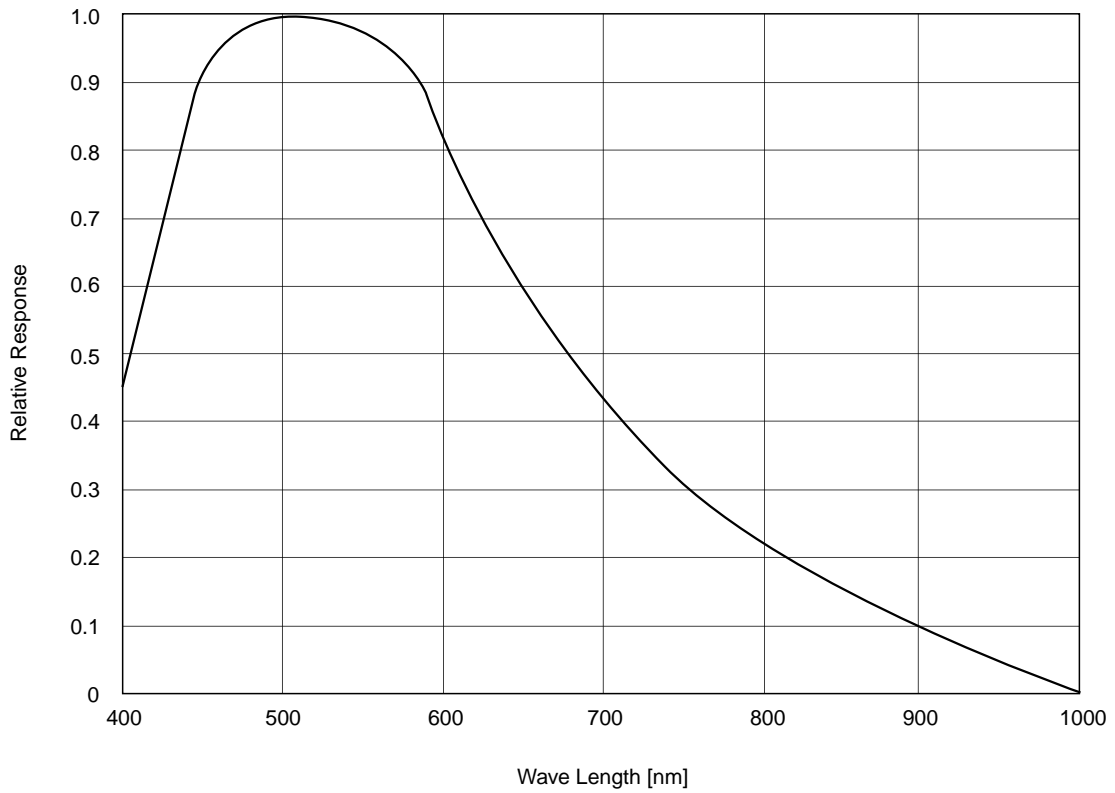

**Sensor Readout Clock Timing Chart**

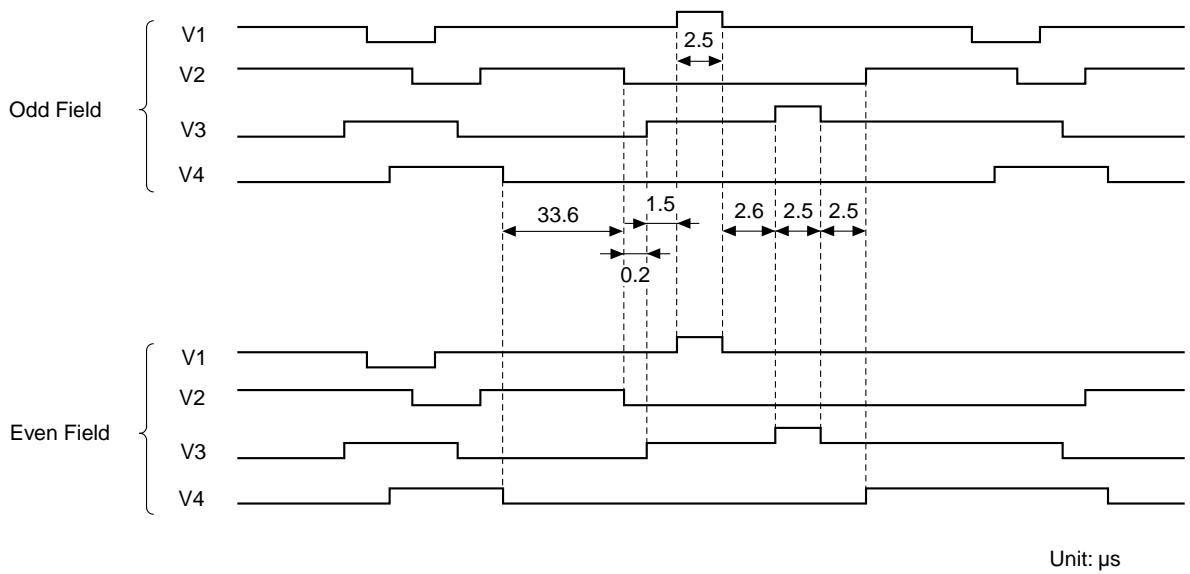

Drive Timing Chart (Vertical Sync)

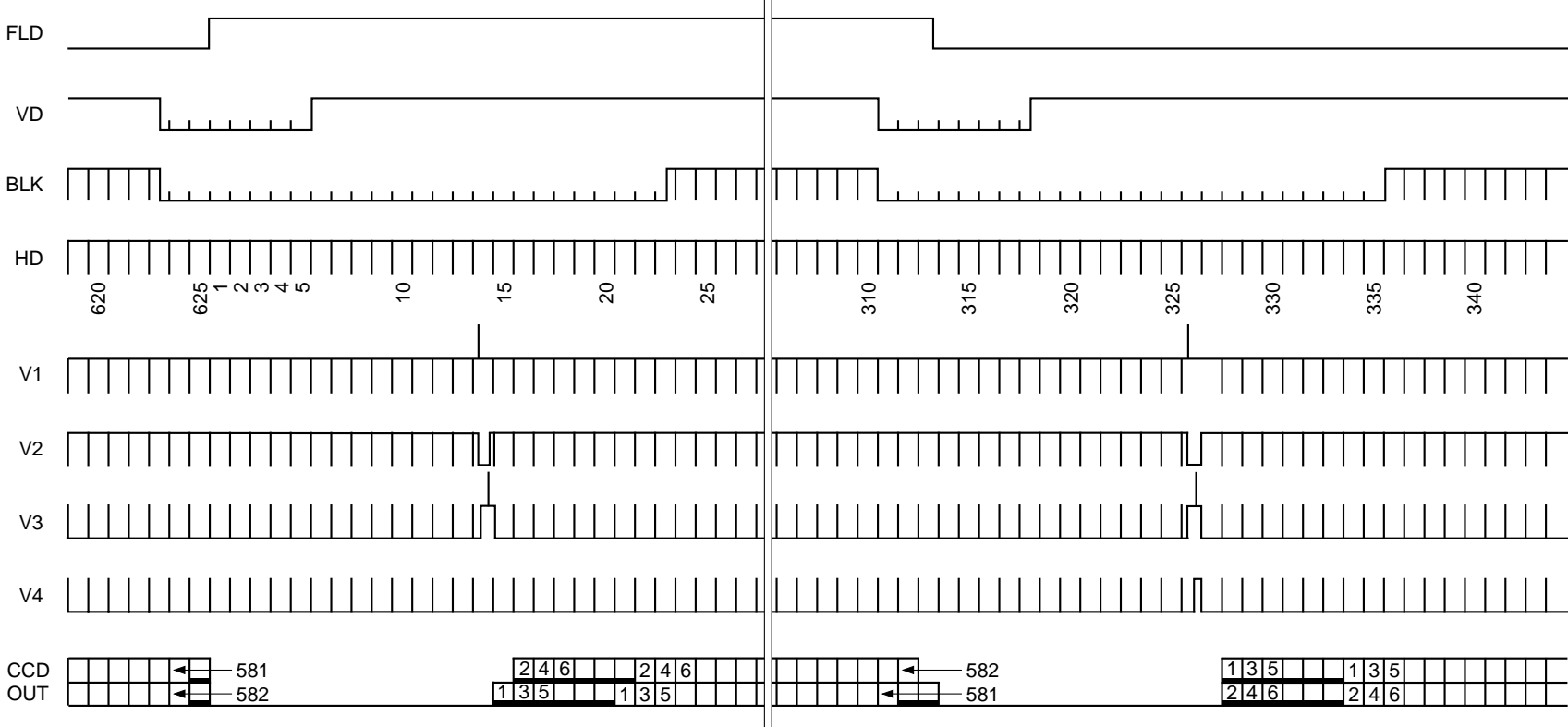

Drive Timing Chart (Horizontal Sync)

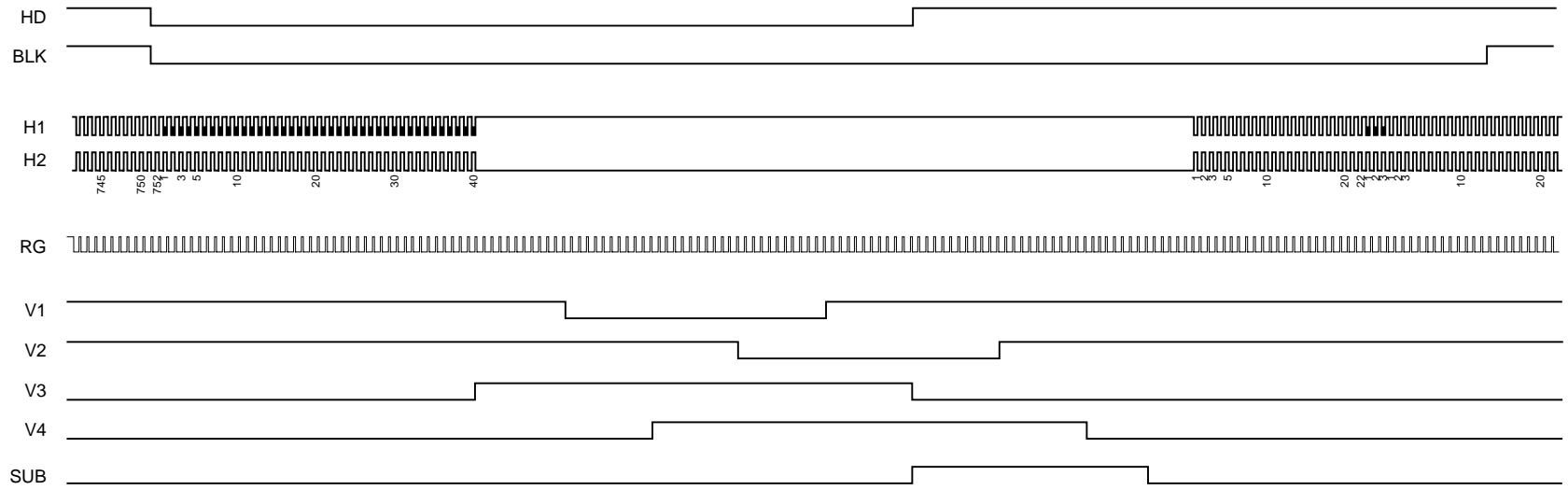

## Notes on Handling

### 1) Static charge prevention

CCD image sensors are easily damaged by static discharge. Before handling be sure to take the following protective measures.

- a) Either handle bare handed or use non-chargeable gloves, clothes or material.  
Also use conductive shoes.
- b) When handling directly use an earth band.
- c) Install a conductive mat on the floor or working table to prevent the generation of static electricity.
- d) Ionized air is recommended for discharge when handling CCD image sensor.
- e) For the shipment of mounted substrates, use boxes treated for the prevention of static charges.

### 2) Soldering

- a) Make sure the package temperature does not exceed 80°C.
- b) Solder dipping in a mounting furnace causes damage to the glass and other defects. Use a 30W soldering iron with a ground wire and solder each pin in less than 2 seconds. For repairs and remount, cool sufficiently.
- c) To dismount an image sensor, do not use a solder suction equipment. When using an electric desoldering tool, use a thermal controller of the zero cross On/Off type and connect it to ground.

### 3) Dust and dirt protection

Image sensors are packed and delivered by taking care of protecting its glass plates from harmful dust and dirt. Clean glass plates with the following operation as required, and use them.

- a) Operate in clean environments (around class 1000 is appropriate).
- b) Do not either touch glass plates by hand or have any object come in contact with glass surfaces.  
Should dirt stick to a glass surface, blow it off with an air blower. (For dirt stuck through static electricity ionized air is recommended.)
- c) Clean with a cotton bud and ethyl alcohol if the grease stained. Be careful not to scratch the glass.
- d) Keep in a case to protect from dust and dirt. To prevent dew condensation, preheat or precool when moving to a room with great temperature differences.
- e) When a protective tape is applied before shipping, just before use remove the tape applied for electrostatic protection. Do not reuse the tape.

### 4) Do not expose to strong light (sun rays) for long periods. For continuous using under cruel condition exceeding the normal using condition, consult our company.

### 5) Exposure to high temperature or humidity will affect the characteristics. Accordingly avoid storage or usage in such conditions.

### 6) CCD image sensors are precise optical equipment that should not be subject to too much mechanical shocks.

Package Outline

Unit: mm

20 pin DIP (800mil)

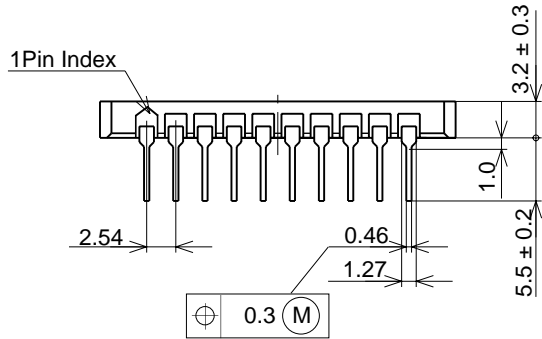
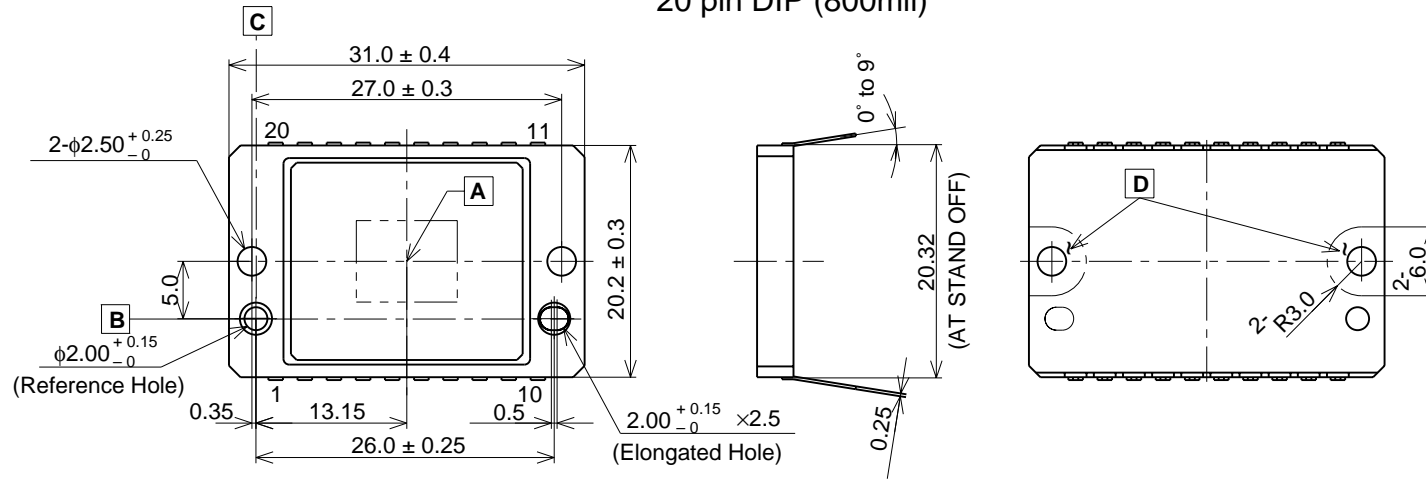

PACKAGE STRUCTURE

PACKAGE MATERIAL	Ceramic
LEAD TREATMENT	GOLD PLATING
LEAD MATERIAL	42 ALLOY
PACKAGE MASS	5.90g
DRAWING NUMBER	AS-A3-02(E)

- "A" is the center of the effective image area.
- The straight line "B" which passes through the center of the reference hole and the elongated hole is the reference axis of vertical direction (V).
- The straight line "C" which passes through the center of the reference hole at right angle to vertical reference line "B" is the reference axis of horizontal direction (H).
- The bottom "D" is the height reference. (Two points are specified.)
- The center of the effective image area specified relative to the reference hole is (H, V) = (13.15, 5.0) ± 0.15mm.
- The angle of rotation relative to the reference line "B" is less than ± 1°
- The height from the bottom "D" to the effective image area is 1.46 ± 0.15mm.
- The tilt of the effective image area relative to the bottom "D" is less than 60µm.
- The thickness of the cover glass is 0.75mm and the refractive index is 1.5.