

**1/3-inch CCD Image Sensor for CCIR B/W Video Cameras *Preliminary***

**Description**

The ICX255AL is an interline CCD solid-state image sensor suitable for CCIR B/W video cameras with a 1/3-inch optical system. Compared with the current product ICX055BL, basic characteristics such as sensitivity, smear, dynamic range and S/N are improved drastically from visible light region to near infrared light region through the adoption of EXview HAD CCD™ technology.

This chip features a field period readout system and an electronic shutter with variable charge-storage time.

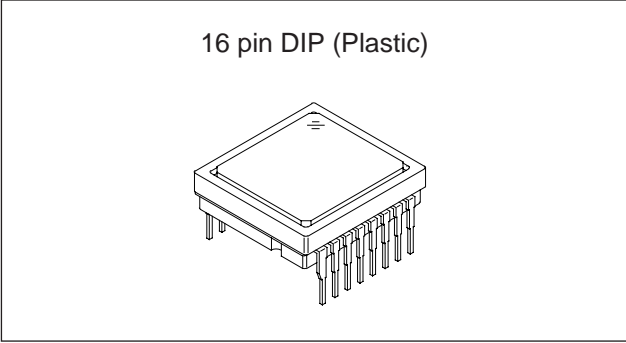

**Features**

- Sensitivity in near infrared light region  
(+8dB compared with the ICX055BL,  $\lambda = 945\text{nm}$ )
- High sensitivity (+6dB compared with the ICX055BL, no IR cut filter)
- Low smear (-20dB compared with the ICX055BL)
- High D range (+3dB compared with the ICX055BL)
- High S/N
- Low dark current
- Excellent antiblooming characteristics
- Continuous variable-speed shutter
- No voltage adjustment  
(Reset gate and substrate bias are not adjusted.)
- Reset gate: 5V drive
- Horizontal register: 5V drive

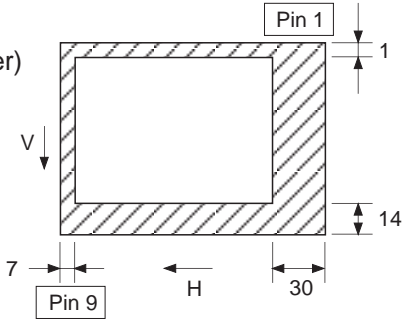

**Optical black position  
(Top View)**

**Device Structure**

- Interline CCD image sensor
- Optical size: 1/3-inch format
- Number of effective pixels: 500 (H) × 582 (V) approx. 290K pixels
- Total number of pixels: 537 (H) × 597 (V) approx. 320K pixels
- Chip size: 6.00mm (H) × 4.96mm (V)
- Unit cell size: 9.8 $\mu\text{m}$  (H) × 6.3 $\mu\text{m}$  (V)
- Optical black:
  - Horizontal (H) direction : Front 7 pixels, rear 30 pixels
  - Vertical (V) direction : Front 14 pixels, rear 1 pixels
- Number of dummy bits:
  - Horizontal 16
  - Vertical 1 (even fields only)
- Substrate material: Silicon

**EXview HAD CCD™**

\* EXview HAD CCD is a trademark of Sony Corporation.  
EXview HAD CCD is a CCD that drastically improves light efficiency by including near infrared light region as a basic structure of HAD (Hole-Accumulation-Diode) sensor.

Sony reserves the right to change products and specifications without prior notice. This information does not convey any license by any implication or otherwise under any patents or other right. Application circuits shown, if any, are typical examples illustrating the operation of the devices. Sony cannot assume responsibility for any problems arising out of the use of these circuits.

**Block Diagram and Pin Configuration**  
(Top View)

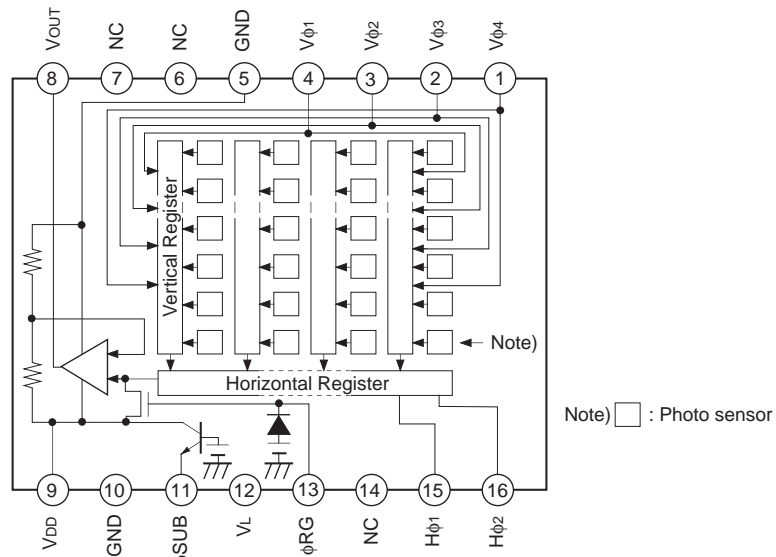

**Pin Description**

Pin No.	Symbol	Description	Pin No.	Symbol	Description
1	V $\phi$ 4	Vertical register transfer clock	9	V <sub>DD</sub>	Supply voltage
2	V $\phi$ 3	Vertical register transfer clock	10	GND	GND
3	V $\phi$ 2	Vertical register transfer clock	11	$\phi$ SUB	Substrate clock
4	V $\phi$ 1	Vertical register transfer clock	12	V <sub>L</sub>	Protective transistor bias
5	GND	GND	13	$\phi$ RG	Reset gate clock
6	NC		14	NC	
7	NC		15	H $\phi$ 1	Horizontal register transfer clock
8	V <sub>OUT</sub>	Signal output	16	H $\phi$ 2	Horizontal register transfer clock

**Absolute Maximum Ratings**

Item		Ratings	Unit	Remarks
Against $\phi$ SUB	V <sub>DD</sub> , V <sub>OUT</sub> , $\phi$ RG – $\phi$ SUB	-40 to +8	V	
	V $\phi$ 1, V $\phi$ 3 – $\phi$ SUB	-50 to +15	V	
	V $\phi$ 2, V $\phi$ 4, V <sub>L</sub> – $\phi$ SUB	-50 to +0.3	V	
	H $\phi$ 1, H $\phi$ 2, GND – $\phi$ SUB	-40 to +0.3	V	
Against GND	V <sub>DD</sub> , V <sub>OUT</sub> , $\phi$ RG – GND	-0.3 to +20	V	
	V $\phi$ 1, V $\phi$ 2, V $\phi$ 3, V $\phi$ 4 – GND	-10 to +18	V	
	H $\phi$ 1, H $\phi$ 2 – GND	-10 to +6	V	
Against V <sub>L</sub>	V $\phi$ 1, V $\phi$ 3 – V <sub>L</sub>	-0.3 to +28	V	
	V $\phi$ 2, V $\phi$ 4, H $\phi$ 1, H $\phi$ 2, GND – V <sub>L</sub>	-0.3 to +15	V	
Between input clock pins	Voltage difference between vertical clock input pins	to +15	V	*1
	H $\phi$ 1 – H $\phi$ 2	-6 to +6	V	
	H $\phi$ 1, H $\phi$ 2 – V $\phi$ 4	-14 to +14	V	
Storage temperature		-30 to +80	°C	
Operating temperature		-10 to +60	°C	

\*1 +24V (Max.) when clock width < 10 $\mu$ s, clock duty factor < 0.1%.

**Bias Conditions**

Item	Symbol	Min.	Typ.	Max.	Unit	Remarks
Supply voltage	V <sub>DD</sub>	14.55	15.0	15.45	V	
Protective transistor bias	V <sub>L</sub>	*1				
Substrate clock	φ <sub>SUB</sub>	*2				
Reset gate clock	φ <sub>RG</sub>	*2				

\*1 V<sub>L</sub> setting is the V<sub>VL</sub> voltage of the vertical transfer clock waveform, or the same power supply as the V<sub>L</sub> power supply for the V driver should be used.

\*2 Do not apply a DC bias to the substrate clock and reset gate clock pins, because a DC bias is generated within the CCD.

**DC Characteristics**

Item	Symbol	Min.	Typ.	Max.	Unit	Remarks
Supply current	I <sub>DD</sub>		3	6	mA	

**Clock Voltage Conditions**

Item	Symbol	Min.	Typ.	Max.	Unit	Waveform diagram	Remarks
Readout clock voltage	V <sub>VT</sub>	14.55	15.0	15.45	V	1	
Vertical transfer clock voltage	V <sub>VH1</sub> , V <sub>VH2</sub>	-0.05	0	0.05	V	2	$V_{VH} = (V_{VH1} + V_{VH2})/2$
	V <sub>VH3</sub> , V <sub>VH4</sub>	-0.2	0	0.05	V	2	
	V <sub>VL1</sub> , V <sub>VL2</sub> , V <sub>VL3</sub> , V <sub>VL4</sub>	-8.0	-7.0	-6.5	V	2	$V_{VL} = (V_{VL3} + V_{VL4})/2$
	V <sub>φV</sub>	6.3	7.0	8.05	V	2	$V_{φV} = V_{VHn} - V_{VLn} (n = 1 \text{ to } 4)$
	V <sub>VH3</sub> - V <sub>VH</sub>	-0.25		0.1	V	2	
	V <sub>VH4</sub> - V <sub>VH</sub>	-0.25		0.1	V	2	
	V <sub>VHH</sub>			0.3	V	2	High-level coupling
	V <sub>VHL</sub>			0.3	V	2	High-level coupling
	V <sub>VLH</sub>			0.3	V	2	Low-level coupling
V <sub>VLL</sub>			0.3	V	2	Low-level coupling	
Horizontal transfer clock voltage	V <sub>φH</sub>	4.75	5.0	5.25	V	3	
	V <sub>H</sub> L	-0.05	0	0.05	V	3	
Reset gate clock voltage	V <sub>φRG</sub>	4.5	5.0	5.5	V	4	Input through 0.1μF capacitance
	V <sub>RGLH</sub> - V <sub>RGLL</sub>			0.4	V	4	Low-level coupling
	V <sub>RGL</sub> - V <sub>RGLm</sub>			0.5	V	4	Low-level coupling
Substrate clock voltage	V <sub>φSUB</sub>	21.0	22.0	23.5	V	5	

**Clock Equivalent Circuit Constant**

Item	Symbol	Min.	Typ.	Max.	Unit	Remarks
Capacitance between vertical transfer clock and GND	$C\phi V1, C\phi V3$		1500		pF	
	$C\phi V2, C\phi V4$		1000		pF	
Capacitance between vertical transfer clocks	$C\phi V12, C\phi V34$		560		pF	
	$C\phi V23, C\phi V41$		330		pF	
	$C\phi V13$		150		pF	
	$C\phi V24$		270		pF	
Capacitance between horizontal transfer clock and GND	$C\phi H1, C\phi H2$		47		pF	
Capacitance between horizontal transfer clocks	$C\phi HH$		22		pF	
Capacitance between reset gate clock and GND	$C\phi RG$		5		pF	
Capacitance between substrate clock and GND	$C\phi SUB$		320		pF	
Vertical transfer clock series resistor	$R1, R3$		75		$\Omega$	
	$R2, R4$		100		$\Omega$	
Vertical transfer clock ground resistor	$R_{GND}$		100		$\Omega$	
Horizontal transfer clock series resistor	$R\phi H$		10		$\Omega$	
Reset gate clock series resistor	$R\phi RG$		50		$\Omega$	

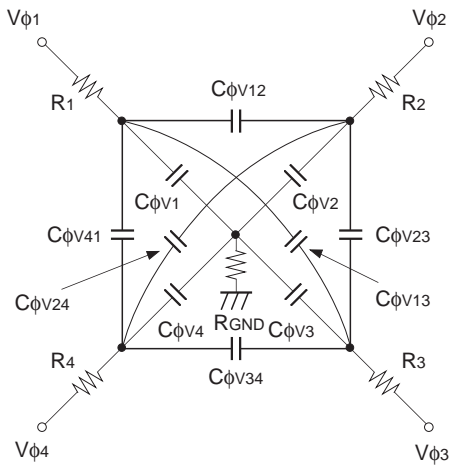

**Vertical transfer clock equivalent circuit**

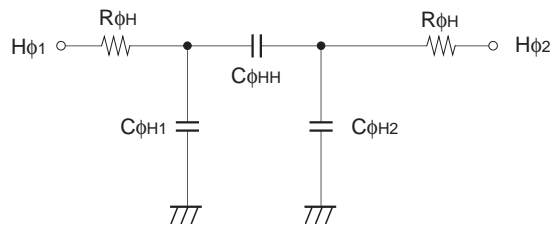

**Horizontal transfer clock equivalent circuit**

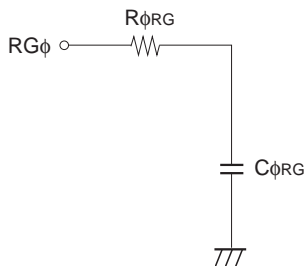

**Reset gate clock equivalent circuit**

Drive Clock Waveform Conditions

(1) Readout clock waveform

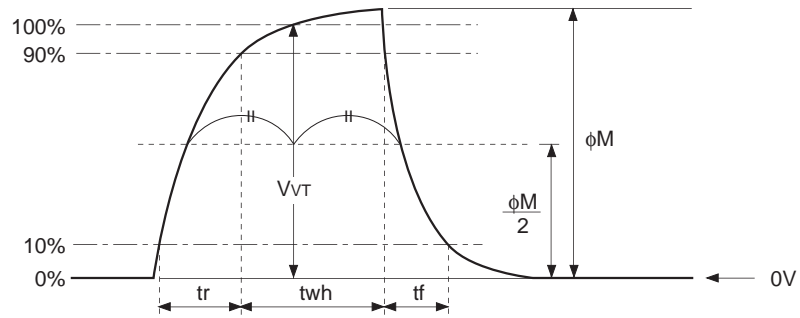

(2) Vertical transfer clock waveform

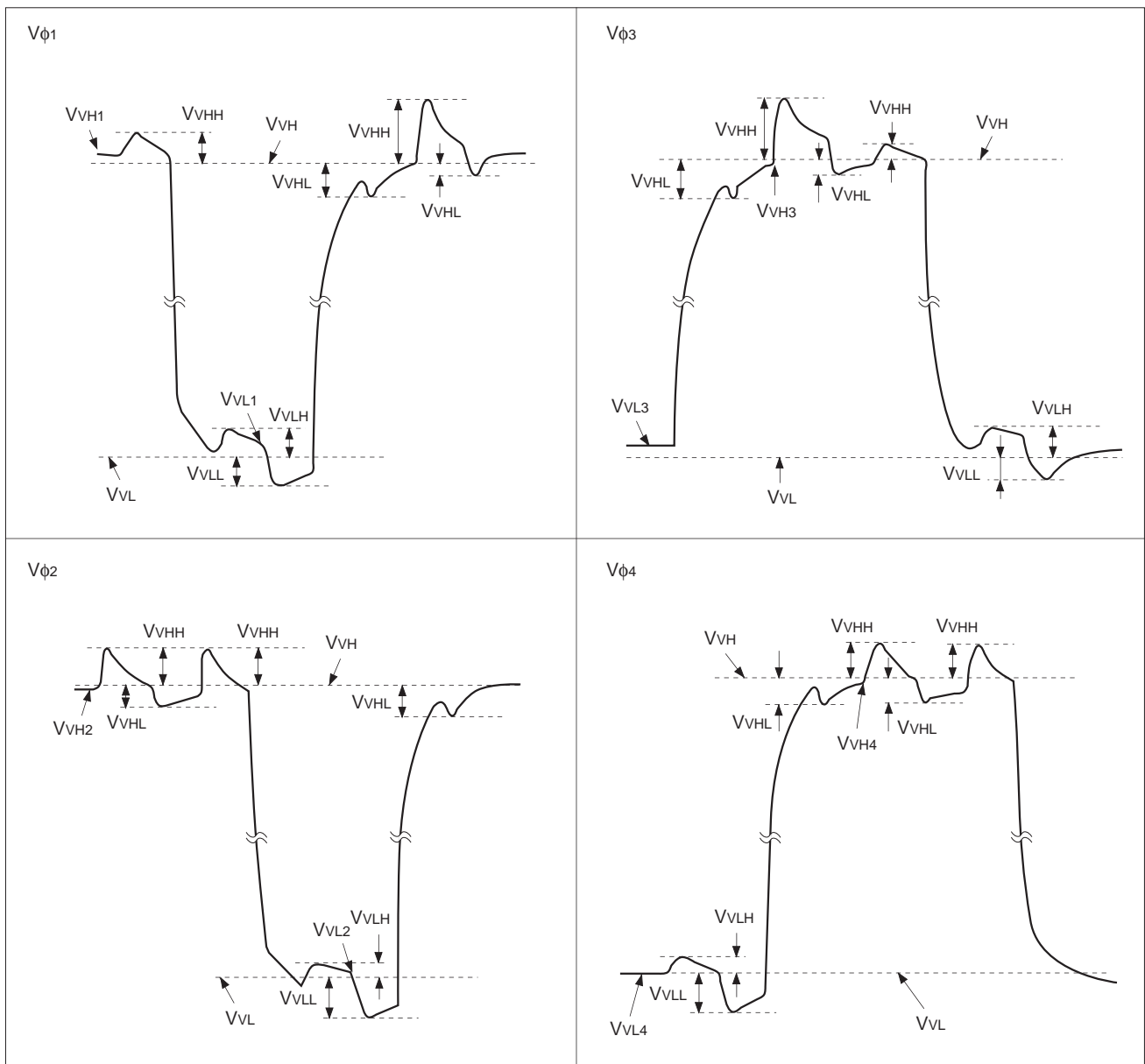

$$V_{vH} = (V_{vH1} + V_{vH2})/2$$

$$V_{vL} = (V_{vL3} + V_{vL4})/2$$

$$V_{\phi v} = V_{vHn} - V_{vLn} \quad (n = 1 \text{ to } 4)$$

**(3) Horizontal transfer clock waveform**



**(4) Reset gate clock waveform**

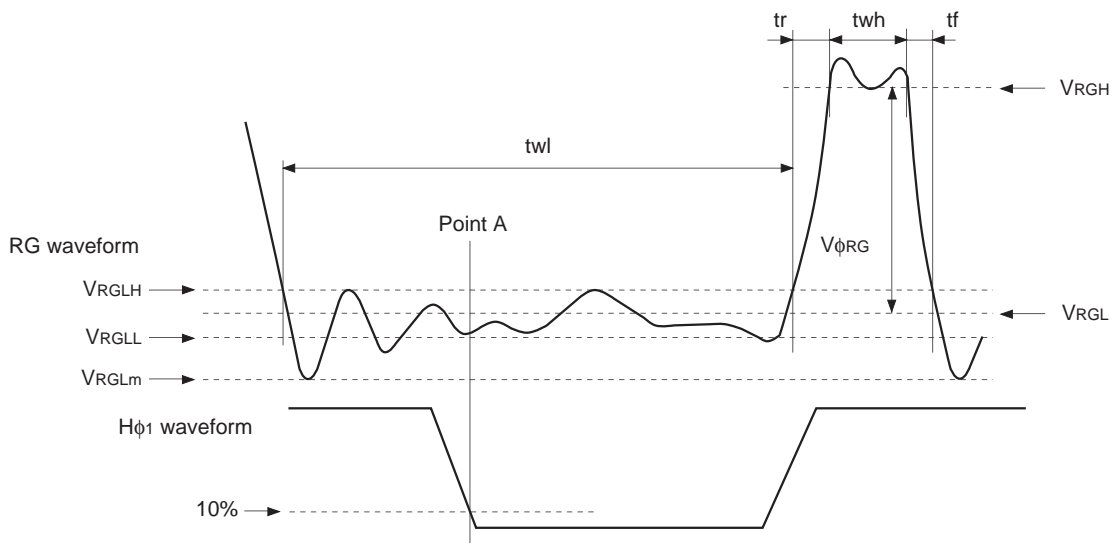

$V_{RGLH}$  is the maximum value and  $V_{RGLL}$  is the minimum value of the coupling waveform during the period from Point A in the above diagram until the rising edge of RG. In addition,  $V_{RGL}$  is the average value of  $V_{RGLH}$  and  $V_{RGLL}$ .

$$V_{RGL} = (V_{RGLH} + V_{RGLL})/2$$

Assuming  $V_{RGH}$  is the minimum value during the interval  $t_{wh}$ , then:

$$V_{\phi RG} = V_{RGH} - V_{RGL}$$

Negative overshoot level during the falling edge of RG is  $V_{RGLm}$ .

**(5) Substrate clock waveform**

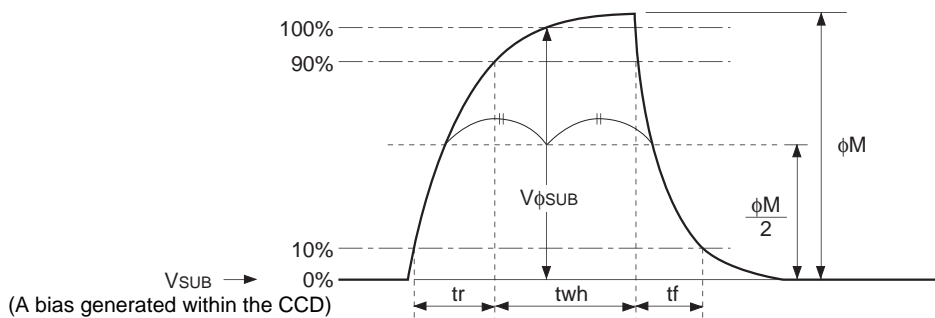

## Clock Switching Characteristics

Item	Symbol	twh			twl			tr			tf			Unit	Remarks	
		Min.	Typ.	Max.	Min.	Typ.	Max.	Min.	Typ.	Max.	Min.	Typ.	Max.			
Readout clock	$V_T$	2.3	2.5						0.5			0.5		$\mu\text{s}$	During readout	
Vertical transfer clock	$V_{\phi 1}, V_{\phi 2}, V_{\phi 3}, V_{\phi 4}$										15		250	ns	*1	
Horizontal transfer clock	During imaging	$H_{\phi}$	37	41		38	42			12	15		10	15	ns	*2
	During parallel-serial conversion	$H_{\phi 1}$		5.6					0.012				0.012		$\mu\text{s}$	
$H_{\phi 2}$						5.6			0.012			0.012				
Reset gate clock	$\phi_{RG}$	11	15		75	79			6.5			4.5		ns		
Substrate clock	$\phi_{SUB}$	1.5	2.0							0.5			0.5	$\mu\text{s}$	During drain charge	

\*1 When vertical transfer clock driver CXD1267AN is used.

\*2  $tf \geq tr - 2\text{ns}$ .

Image Sensor Characteristics

(Ta = 25°C)

Item	Symbol	Min.	Typ.	Max.	Unit	Measurement method	Remarks
Sensitivity	S	1300	1600		mV	1	
Saturation signal	Vsat	1000			mV	2	Ta = 60°C
Smear	Sm		-120	-103	dB	3	
Video signal shading	SH			20	%	4	Zone 0 and I
				25	%	4	Zone 0 to II'
Dark signal	Vdt			2	mV	5	Ta = 60°C
Dark signal shading	$\Delta Vdt$			1	mV	6	Ta = 60°C
Flicker	F			2	%	7	
Lag	Lag			0.5	%	8	

Zone Definition of Video Signal Shading

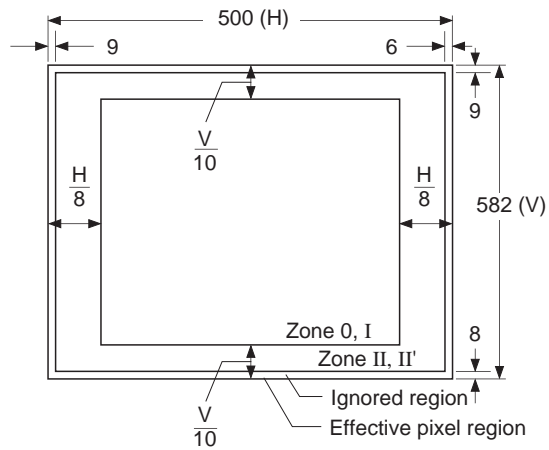



## Image Sensor Characteristics Measurement Method

### ◎ Measurement conditions

- 1) In the following measurements, the device drive conditions are at the typical values of the bias and clock voltage conditions.
- 2) In the following measurements, spot blemishes are excluded and, unless otherwise specified, the optical black (OB) level is used as the reference for the signal output, and the value measured at point [\*A] in the drive circuit example is used.

### ◎ Definition of standard imaging conditions

- 1) Standard imaging condition I:  
Use a pattern box (luminance: 706cd/m<sup>2</sup>, color temperature of 3200K halogen source) as a subject. (Pattern for evaluation is not applicable.) Use a testing standard lens with CM500S (t = 1.0mm) as an IR cut filter and image at F8. The luminous intensity to the sensor receiving surface at this point is defined as the standard sensitivity testing luminous intensity.
- 2) Standard imaging condition II:  
Image a light source (color temperature of 3200K) with a uniformity of brightness within 2% at all angles. Use a testing standard lens with CM500S (t = 1.0mm) as an IR cut filter. The luminous intensity is adjusted to the value indicated in each testing item by the lens diaphragm.
- 3) Standard imaging condition III:  
Image a light source (color temperature of 3200K) with a uniformity of brightness within 2% at all angles. Use a testing standard lens with CM500S (t = 1.0mm) as an IR cut filter. The luminous intensity is adjusted to the value indicated in each testing item by the lens diaphragm.

#### 1. Sensitivity

Set to standard imaging condition I. After selecting the electronic shutter mode with a shutter speed of 1/250s, measure the signal output (Vs) at the center of the screen and substitute the value into the following formula.

$$S = V_s \times \frac{250}{50} \text{ [mV]}$$

#### 2. Saturation signal

Set to standard imaging condition II. After adjusting the luminous intensity to 10 times the intensity with the average value of the signal output, 200mV, measure the minimum value of the signal output.

#### 3. Smear

Set to standard imaging condition II. With the lens diaphragm at F5.6 to F8, adjust the luminous intensity to 500 times the intensity with the average value of the signal output, 200mV. When the readout clock is stopped and the charge drain is executed by the electronic shutter at the respective H blankings, measure the maximum value (VSm [mV]) of the signal output and substitute the value into the following formula.

$$S_m = 20 \times \log \left( \frac{V_{Sm}}{200} \times \frac{1}{500} \times \frac{1}{10} \right) \text{ [dB]} \text{ (1/10V method conversion value)}$$

4. Video signal shading

Set to standard imaging condition III. With the lens diaphragm at F5.6 to F8, adjust the luminous intensity so that the average value of the signal output is 200mV. Then measure the maximum (Vmax [mV]) and minimum (Vmin [mV]) values of the signal output and substitute the values into the following formula.

$$SH = (V_{max} - V_{min})/200 \times 100 [\%]$$

5. Dark signal

Measure the average value of the signal output (Vdt [mV]) with the device ambient temperature 60°C and the device in the light-obstructed state, using the horizontal idle transfer level as a reference.

6. Dark signal shading

After measuring 5, measure the maximum (Vdmax [mV]) and minimum (Vdmin [mV]) values of the dark signal output and substitute the values into the following formula.

$$\Delta V_{dt} = V_{dmax} - V_{dmin} [mV]$$

7. Flicker

Set to standard imaging condition II. Adjust the luminous intensity so that the average value of the signal output is 200mV, and then measure the difference in the signal level between fields ( $\Delta V_f$  [mV]). Then substitute the value into the following formula.

$$F = (\Delta V_f/200) \times 100 [\%]$$

8. Lag

Adjust the signal output value generated by strobe light to 200mV. After setting the strobe light so that it strobes with the following timing, measure the residual signal (Vlag). Substitute the value into the following formula.

$$Lag = (V_{lag}/200) \times 100 [\%]$$

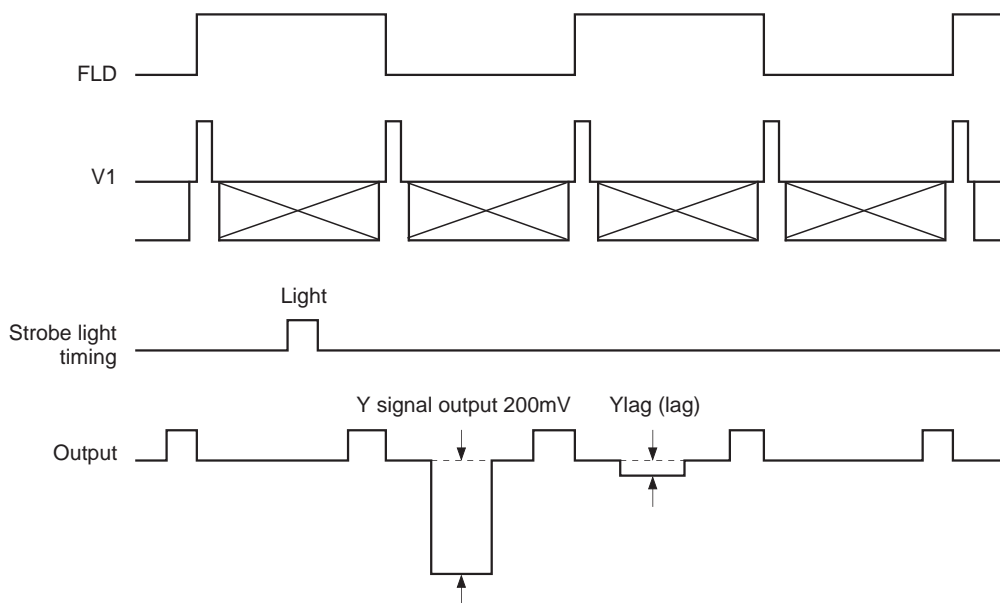

Drive Circuit

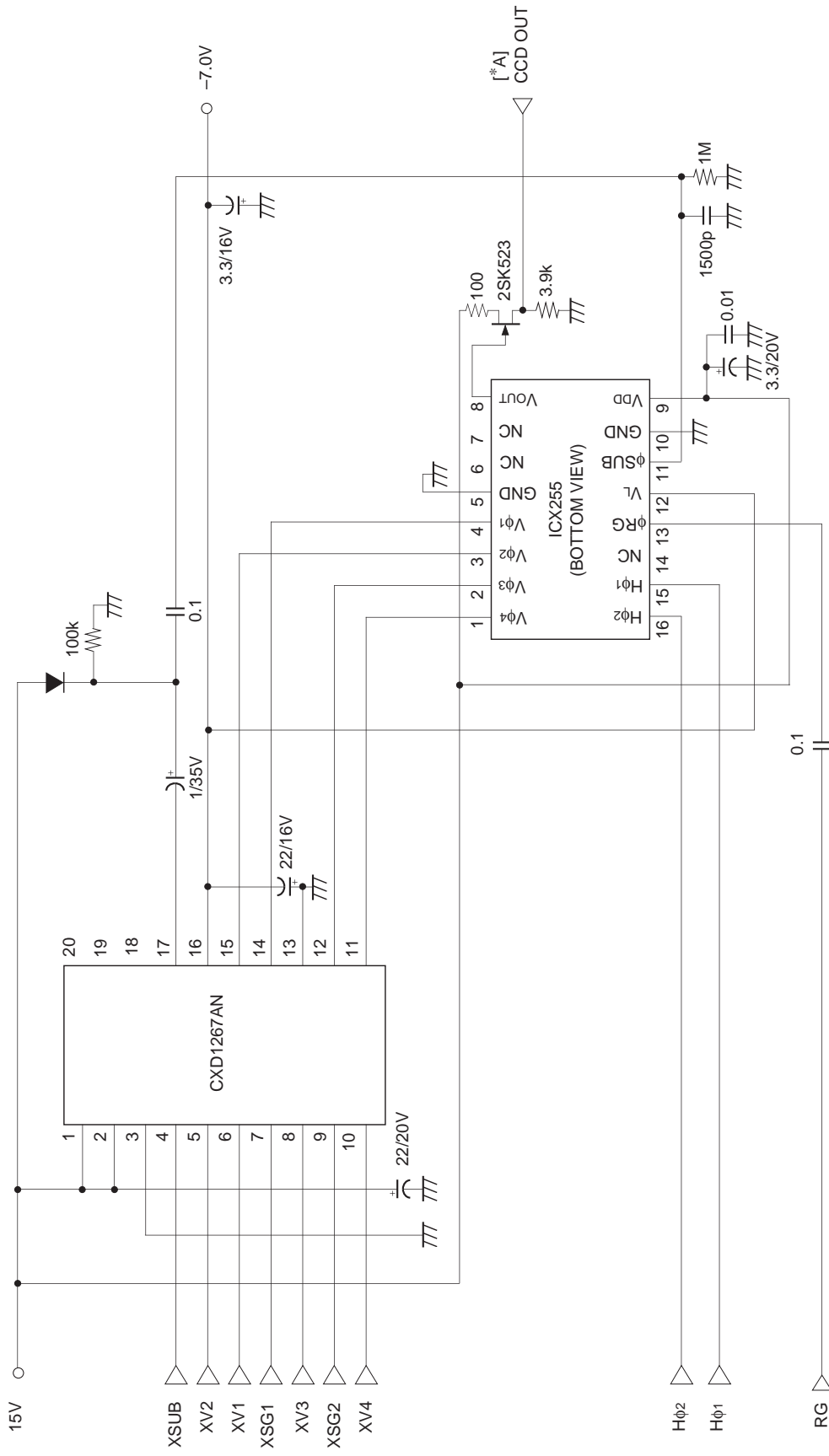

**Spectral Sensitivity Characteristics**

(excludes both lens characteristics and light source characteristics)

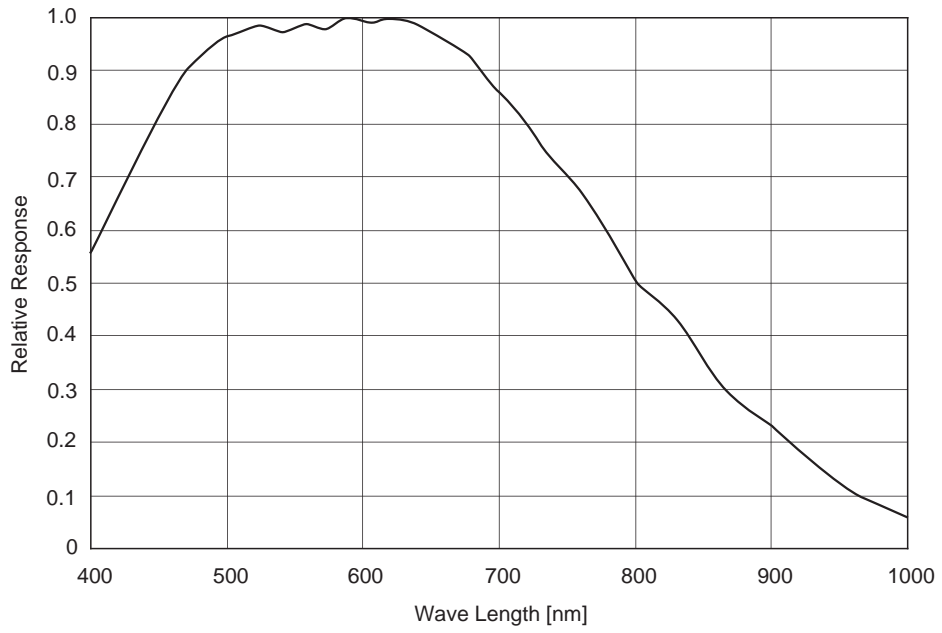

**Sensor Readout Clock Timing Chart**

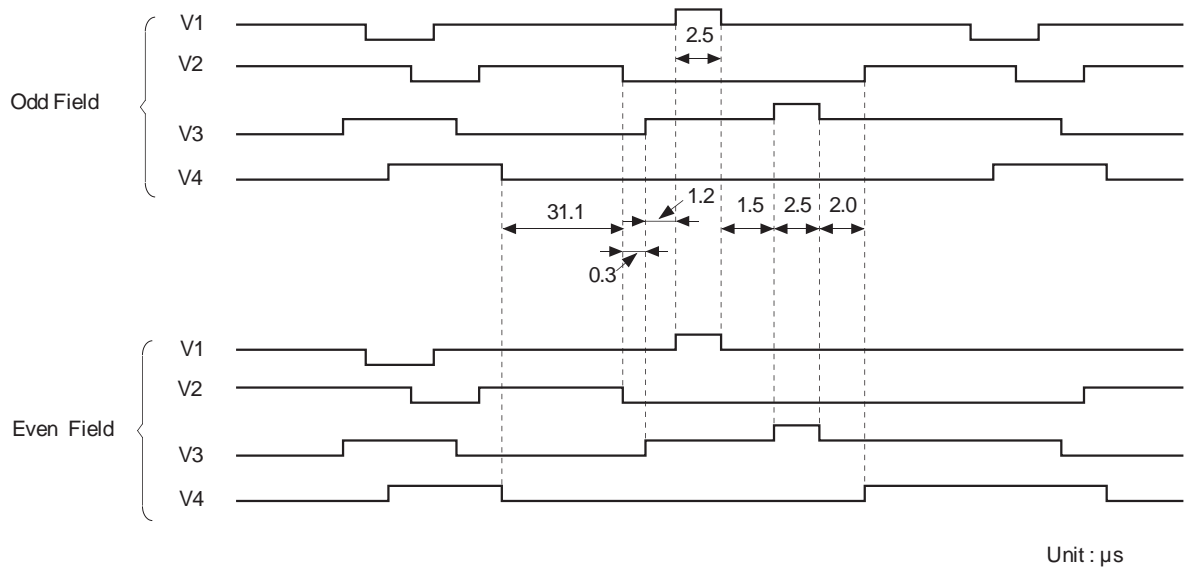

Drive Timing Chart (Vertical Sync)

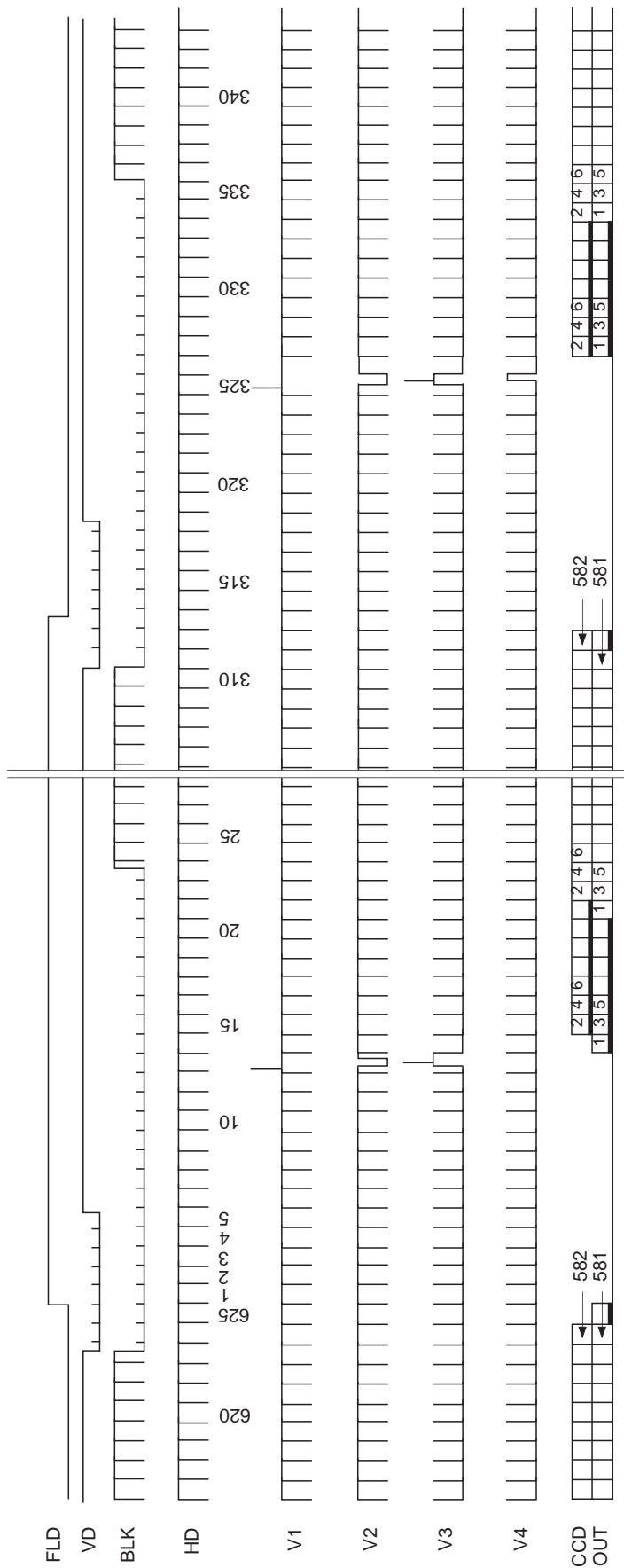

Drive Timing Chart (Horizontal Sync)

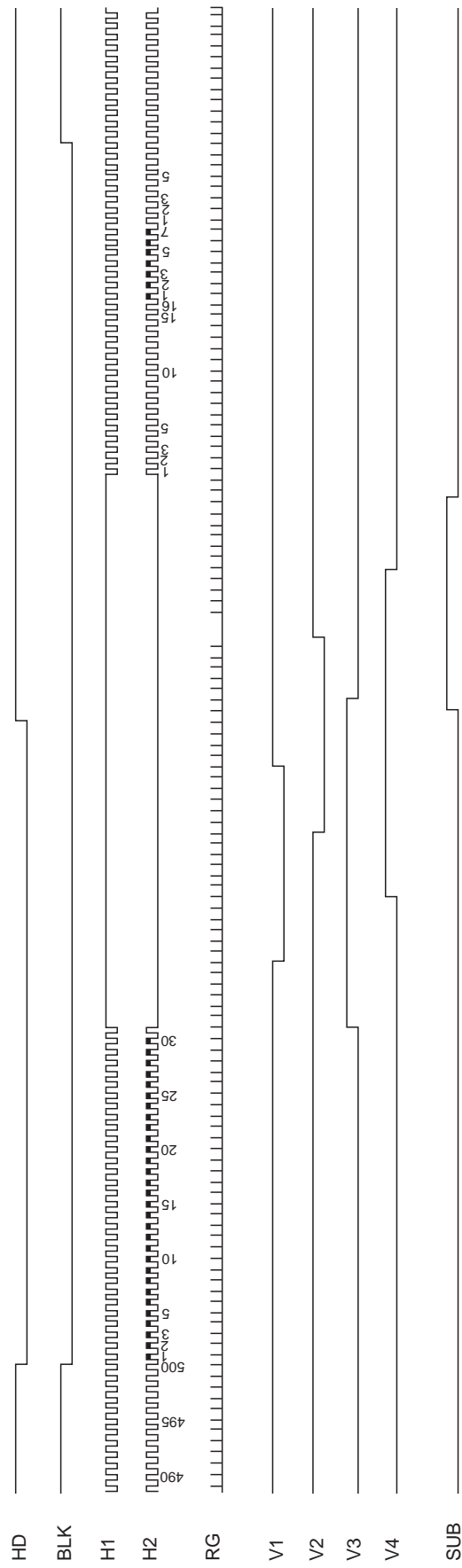

## Notes on Handling

### 1) Static charge prevention

CCD image sensors are easily damaged by static discharge. Before handling be sure to take the following protective measures.

- a) Either handle bare handed or use non-chargeable gloves, clothes or material.  
Also use conductive shoes.
- b) When handling directly use an earth band.
- c) Install a conductive mat on the floor or working table to prevent the generation of static electricity.
- d) Ionized air is recommended for discharge when handling CCD image sensor.
- e) For the shipment of mounted substrates, use boxes treated for the prevention of static charges.

### 2) Soldering

- a) Make sure the package temperature does not exceed 80°C.
- b) Solder dipping in a mounting furnace causes damage to the glass and other defects. Use a ground 30W soldering iron and solder each pin in less than 2 seconds. For repairs and remount, cool sufficiently.
- c) To dismount an image sensor, do not use a solder suction equipment. When using an electric desoldering tool, use a thermal controller of the zero cross On/Off type and connect it to ground.

### 3) Dust and dirt protection

Image sensors are packed and delivered by taking care of protecting its glass plates from harmful dust and dirt. Clean glass plates with the following operation as required, and use them.

- a) Perform all assembly operations in a clean room (class 1000 or less).
- b) Do not either touch glass plates by hand or have any object come in contact with glass surfaces. Should dirt stick to a glass surface, blow it off with an air blower. (For dirt stuck through static electricity ionized air is recommended.)
- c) Clean with a cotton bud and ethyl alcohol if the grease stained. Be careful not to scratch the glass.
- d) Keep in a case to protect from dust and dirt. To prevent dew condensation, preheat or precool when moving to a room with great temperature differences.
- e) When a protective tape is applied before shipping, just before use remove the tape applied for electrostatic protection. Do not reuse the tape.

### 4) Installing (attaching)

- a) Remain within the following limits when applying a static load to the package. Do not apply any load more than 0.7mm inside the outer perimeter of the glass portion, and do not apply any load or impact to limited portions. (This may cause cracks in the package.)

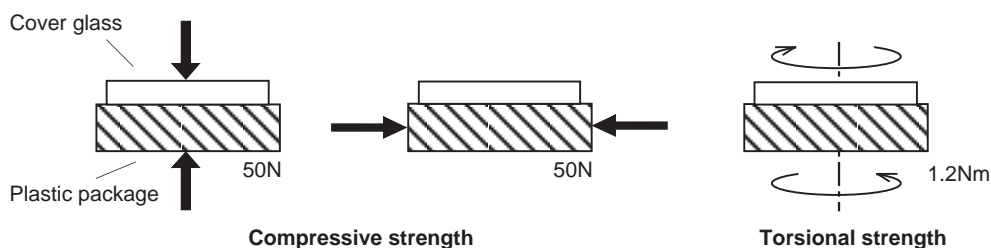

- b) If a load is applied to the entire surface by a hard component, bending stress may be generated and the package may fracture, etc., depending on the flatness of the bottom of the package. Therefore, for installation, use either an elastic load, such as a spring plate, or an adhesive.
- c) The adhesive may cause the marking on the rear surface to disappear, especially in case the regulated voltage value is indicated on the rear surface. Therefore, the adhesive should not be applied to this area, and indicated values should be transferred to the other locations as a precaution.
- d) The notch of the package is used for directional index, and that can not be used for reference of fixing. In addition, the cover glass and seal resin may overlap with the notch of the package.
- e) If the lead bend repeatedly and the metal, etc., clash or rub against the package, the dust may be generated by the fragments of resin.
- f) Acrylate anaerobic adhesives are generally used to attach CCD image sensors. In addition, cyanoacrylate instantaneous adhesives are sometimes used jointly with acrylate anaerobic adhesives. (reference)

#### 5) Others

- a) Do not expose to strong light (sun rays) for long periods. For continuous using under cruel condition exceeding the normal using condition, consult our company.
- b) Exposure to high temperature or humidity will affect the characteristics. Accordingly avoid storage or usage in such conditions.
- c) The brown stain may be seen on the bottom or side of the package. But this does not affect the CCD characteristics.
- d) This CCD image sensor has sensitivity in the near infrared area. Its focus may not match in the same condition under visible light /near infrared light because of aberration.



Package Outline Unit: mm

16pin DIP (450mil)

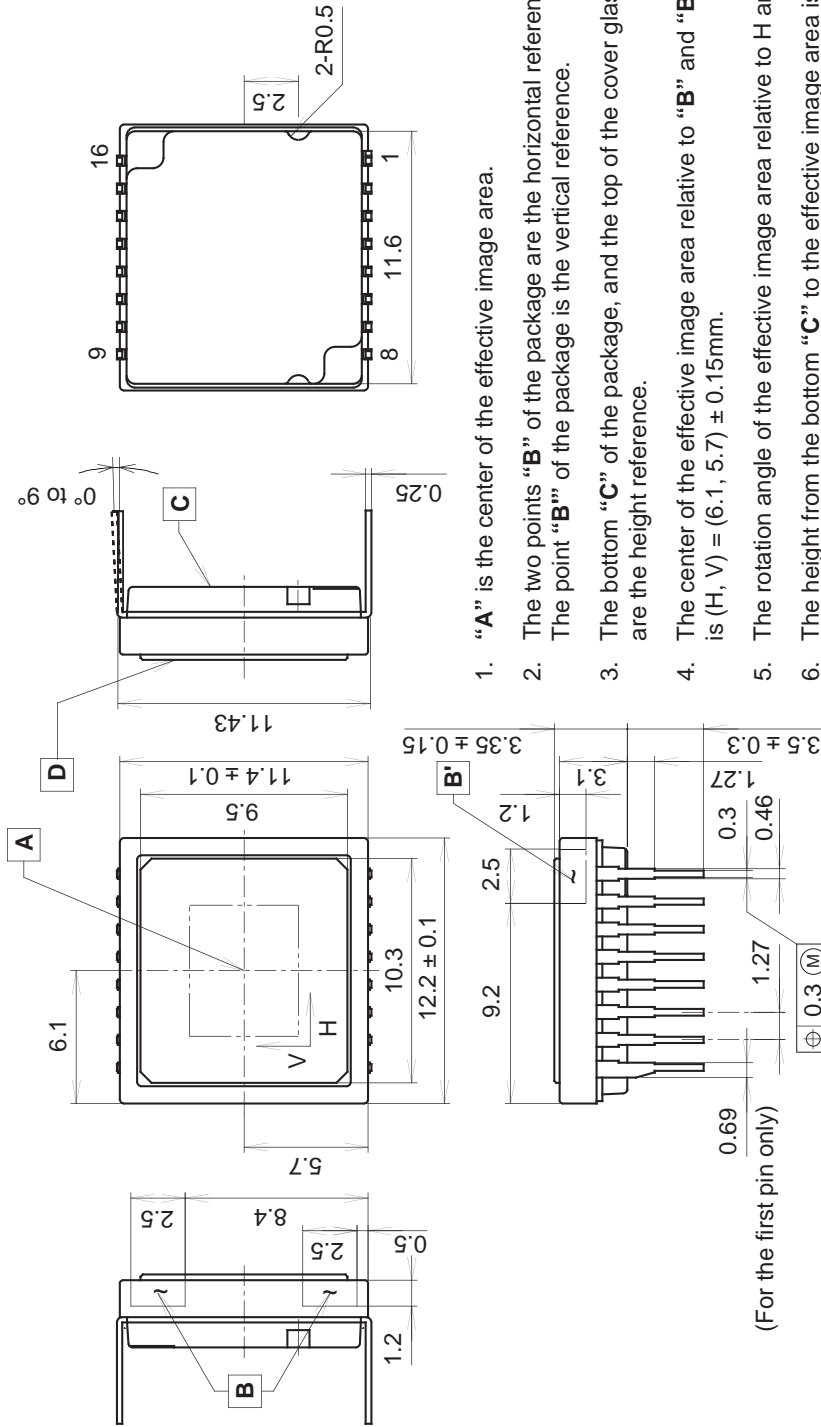

1. "A" is the center of the effective image area.
2. The two points "B" of the package are the horizontal reference. The point "B'" of the package is the vertical reference.
3. The bottom "C" of the package, and the top of the cover glass "D" are the height reference.
4. The center of the effective image area relative to "B" and "B'" is  $(H, V) = (6.1, 5.7) \pm 0.15\text{mm}$ .
5. The rotation angle of the effective image area relative to H and V is  $\pm 1^\circ$ .
6. The height from the bottom "C" to the effective image area is  $1.41 \pm 0.10\text{mm}$ . The height from the top of the cover glass "D" to the effective image area is  $1.94 \pm 0.15\text{mm}$ .
7. The tilt of the effective image area relative to the bottom "C" is less than  $50\mu\text{m}$ . The tilt of the effective image area relative to the top "D" of the cover glass is less than  $50\mu\text{m}$ .
8. The thickness of the cover glass is  $0.75\text{mm}$ , and the refractive index is 1.5.
9. The notches on the bottom of the package are used only for directional index, they must not be used for reference of fixing.

PACKAGE STRUCTURE

PACKAGE MATERIAL	Plastic
LEAD TREATMENT	GOLD PLATING
LEAD MATERIAL	42 ALLOY
PACKAGE WEIGHT	0.9g